

THE PENNSYLVANIA STATE UNIVERSITY
DEPARTMENT OF ENERGY AND MINERAL ENGINEERING
ENVSE 408 CONTAMINANT HYDROLOGY

Mid-term Examination – Tuesday February 26th, 2019 – 75 minutes

Answer all three questions.

For water (in contact with air): $\sigma = 7.3 \times 10^{-2} \text{ N/m}$; $\mu = 1.12 \times 10^{-3} \text{ N.s/m}^2$

Name: _____

Question	Points	Score
1	100	
2	100	
3	100	
Total	300	

Question 1

Define the following terms, and identify the units [MLT] of the quantity, where relevant. Be as specific and as exhaustive in your definitions as possible.

1. Dispersivities, α_L, α_T .

2. Bubbling pressure, p_{c0}

3. Capillary pressure versus saturation relationship defined in terms of the Leverett J-function, J .

4. Gaseous retardation factor, R_g .

Question 2

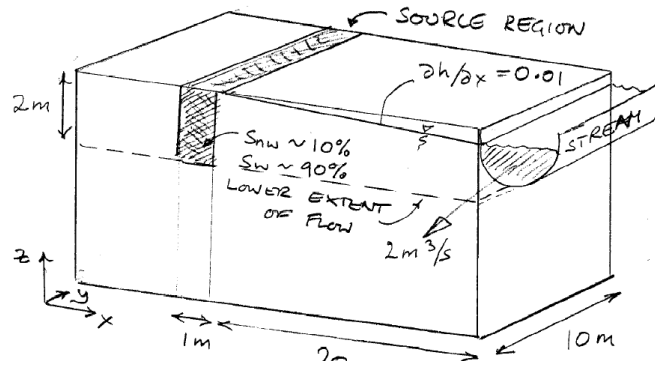

A surface spill of gasoline has penetrated into the subsurface. It previously rested on the groundwater table, which has fallen and subsequently risen, to smear it as shown. The floating free-product has been removed, and the smeared zone is below the water table and at a residual saturation of 90% water and 10% LNAPL.

The hydraulic conductivity of the aquifer is $K = 10^{-4} \text{ m/s}$, and is at a relative permeability of $k_r = 1$ for water. The aquifer has a porosity of $n = 20\%$, and retardation is insignificant. The LNAPL is immobile, and comprises a single principal component of ethyl-benzene with a solubility of 140 mg/l and a density of 867 g/L. Assume an effective diffusion coefficient of the dissolved component to be $D^* = 10^{-9} \text{ m}^2/\text{s}$. And a longitudinal dispersivity of α_L of one tenth of plume length.

The figures show the solution for the advection-diffusion equation for a constant upstream concentration (fixed step concentration), c_0 , with Peclet number, $Pe = v_x L / D$, and pore volumes of flow past a point downstream at coordinate $x = L$, of $t_R = v_x t / L$, i.e. the solution for:

$$c / c_0 = 1 / 2 [\text{erfc}(Pe / 4t_R)^{1/2} (1 - t_R) + \exp(Pe) \text{erfc}(Pe / 4t_R)^{1/2} (1 + t_R)]$$

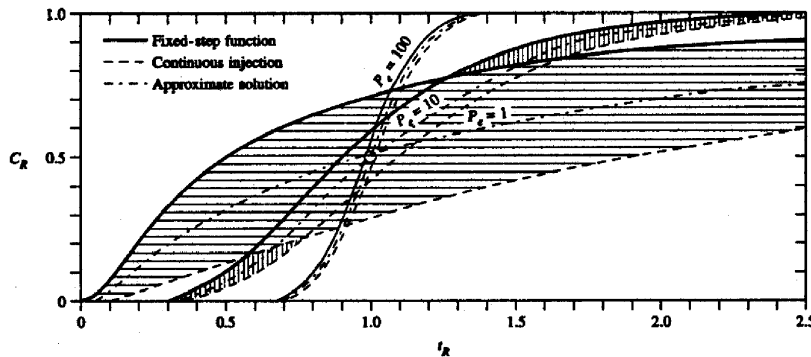

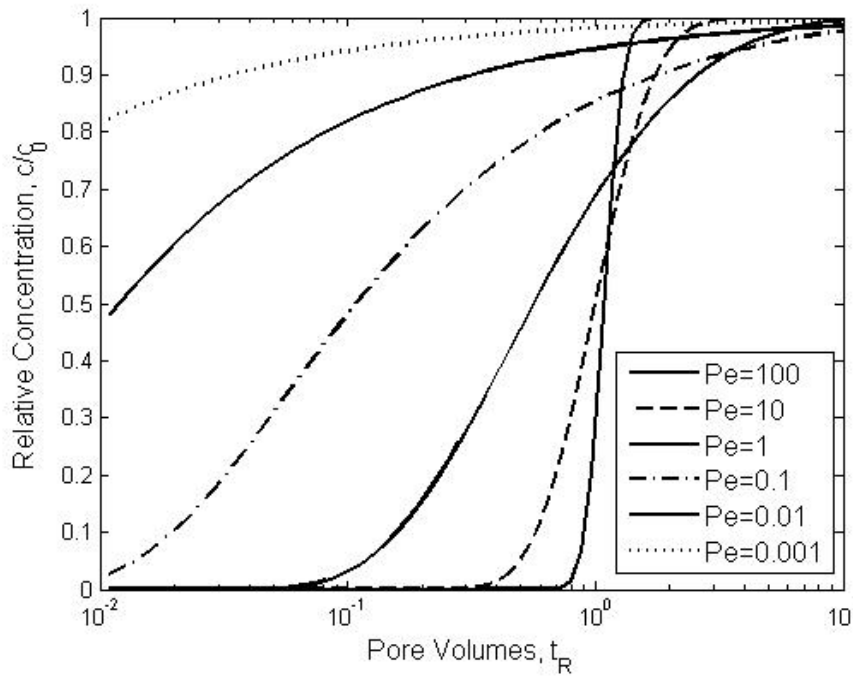

1. Evaluate the arrival time of the mean concentration to the stream of ethyl-benzene. What are the approximate times of the 0.1 (10%) and 0.9 (90%) c/c_0 arrivals?

2. What is the concentration of ethyl-benzene when the plume arrives at the downstream extent of the aquifer, immediately before discharging into the stream (i.e. the equilibrium concentration)?

3. At this rate of transport from the source, approximately how long will it take to deplete the source by dissolution?
4. The dissolved flux enters the stream, with the stream flowing at a rate of $2 \text{ m}^3/\text{s}$. To what average dissolved concentration of ethyl-benzene is aquatic life exposed? The plume is 10 m wide and ~ 2 m deep.

5. If grouting the material between the source and the stream is used to slow the spread of the components, and the mean permeability is reduced to $K = 10^{-10} \text{ m/s}$, and the porosity to 2%, what is the new reduced mass loading to the stream, and the resulting concentration in the stream?

6. At this loading, how long-lived would the plume be?

Question 3

Given the attached curve for hydraulic conductivity (K) versus volumetric water content (θ) relation for a core originally saturated with water and subject to drying:

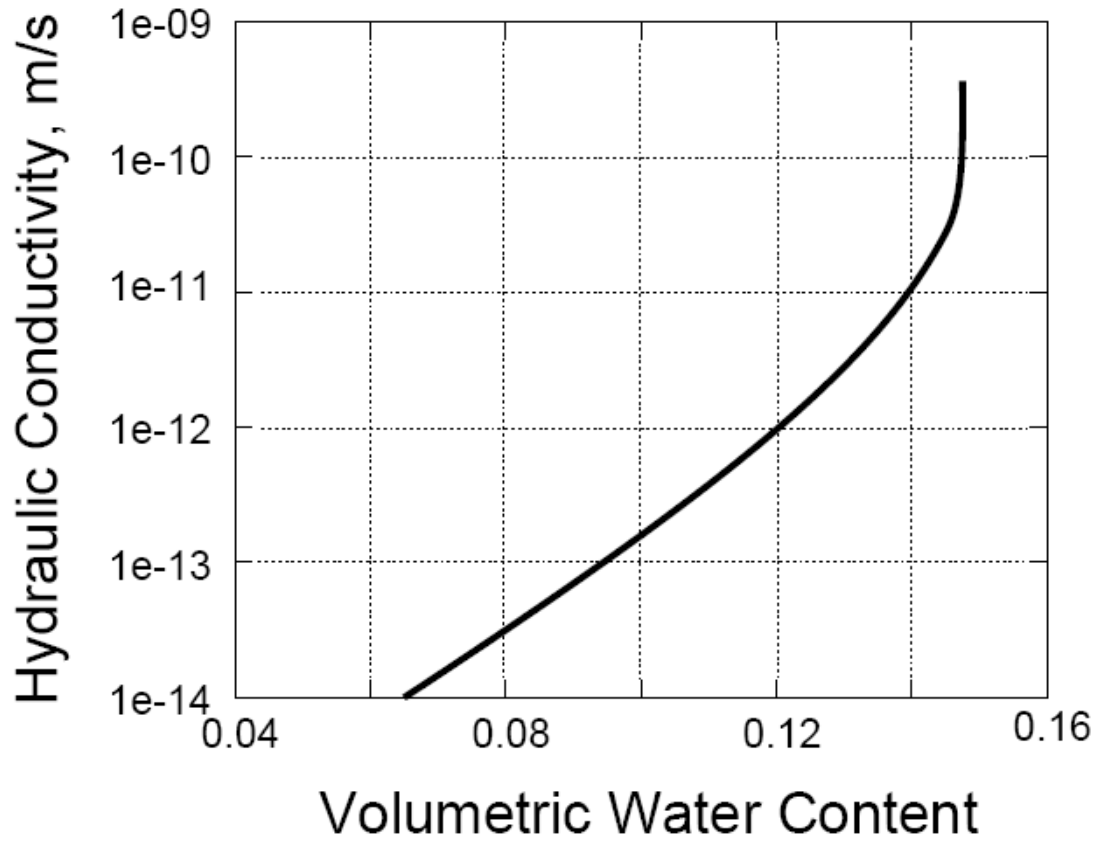

1. Determine the relative permeability at a water saturation of 80%.

2. If this is the measured field saturation, evaluate the maximum infiltration flux possible at this saturation. Recall that during infiltration, the only agent driving flow is gravity, *i.e.* $\partial h / \partial z = 1$.

3. These data are for Topopah Springs Tuff. Evaluate the maximum infiltration (per square meter of plan area) per year. Again, only gravity drives the flow.